

Technical data sheet



Product features

Electric fryer 2 baskets 0,8 kW/l, 17+17 l on cabinet 400 V

Model	SAP Code	00110054
--------------	-----------------	----------



- Basin volume [l]: 17+17
- Drain type: Trough the cabinet
- Drain: Yes
- Maximum device temperature [°C]: 190
- Minimum device temperature [°C]: 50
- Material: AISI 304 top plate, AISI 430 cladding
- Heating location: Inside the tank
- Number of baskets: 2
- Basket size [mm]: 2x 280 x 300 x 120

SAP Code	00110054	Loading	400 V / 3N - 50 Hz
Net Width [mm]	800	Basin volume [l]	17+17
Net Depth [mm]	700	Number of basins	2
Net Height [mm]	900	Number of baskets	2
Net Weight [kg]	79.00	Basket size [mm]	2x 280 x 300 x 120
Power electric [kW]	27.000	Ratio power/volume [kW/l]	0.80

Technical data sheet



Technical drawing

Electric fryer 2 baskets 0,8 kW/l, 17+17 l on cabinet 400 V

Model

SAP Code

00110054

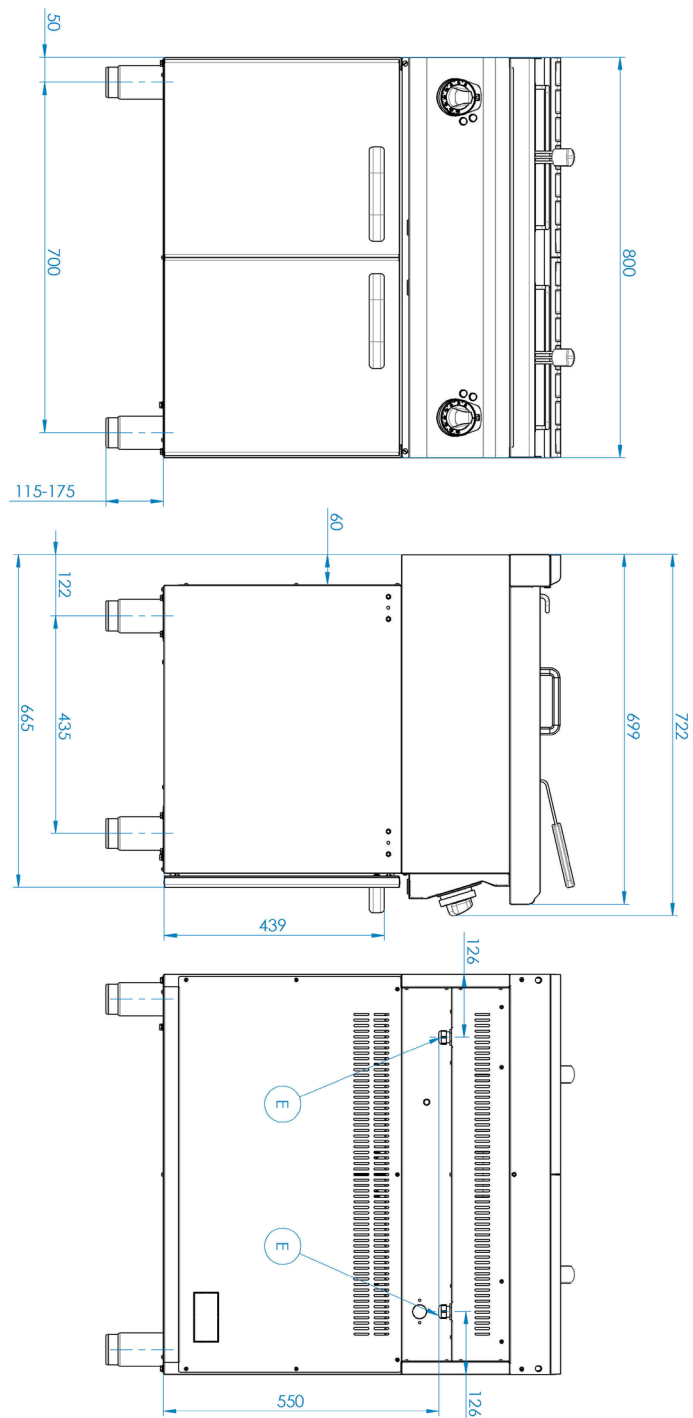

Electric fryer 2 baskets 0,8 kW/l, 17+17 l on cabinet 400 V

Model

SAP Code

00110054

1

All-stainless steel bathtub

long life
resistance of AISI 304 stainless steel material
the material does not cut

- savings on service interventions
- easier and faster operation

2

Degree of protection of the control elements IPX4

maintenance-free system
resistance to splash water
long life

- savings on service interventions
- easy cleaning and maintenance of equipment

3

Outlet into a removable collector in the base with a sieve against coarse dirt

outlet of the bath into the prepared container

- easy and safe handling

4

Cold zone

prevents food residues from burning
there is no change in the taste of the oil

- longer oil life
- easy access and maintenance

5

Rotating heating element

longer lifetime
easy access

- effective cleaning when the body is tipped out
- easy access even to corners and time saving

6

High power consumption/l

quick run-up to operating temperature after inserting the product

- food is not soaked in oil, tastes better and is ready sooner
- more production

Technical data sheet



Technical parameters

Electric fryer 2 baskets 0,8 kW/l, 17+17 l on cabinet 400 V

Model

SAP Code

00110054

1. SAP Code:

00110054

2. Net Width [mm]:

800

3. Net Depth [mm]:

700

4. Net Height [mm]:

900

5. Net Weight [kg]:

79.00

6. Gross Width [mm]:

840

7. Gross depth [mm]:

800

8. Gross Height [mm]:

975

9. Gross Weight [kg]:

92.00

10. Device type:

Electric unit

11. Construction type of device:

With substructure

12. Power electric [kW]:

27.000

13. Loading:

400 V / 3N - 50 Hz

14. Protection of controls:

IPX4

15. Exterior color of the device:

Stainless steel

16. Material:

AISI 304 top plate, AISI 430 cladding

17. Worktop type:

Molded - comfortable cleaning maintenance

18. Worktop material:

Stainless steel

19. Worktop Thickness [mm]:

1.20

20. Device heating type:

Direct

21. Standard equipment for device:

lid and basket

22. Basin volume [l]:

17+17

23. Basin dimensions [mm x mm x mm]:

300 x 342 x 244

24. Maximum device temperature [°C]:

190

25. Minimum device temperature [°C]:

50

26. Safety thermostat:

Yes

27. Adjustable feet:

Yes

28. Heating element material:

AISI 304

Technical data sheet



Technical parameters

Electric fryer 2 baskets 0,8 kW/l, 17+17 l on cabinet 400 V

Model

SAP Code

00110054

29. Number of baskets:

2

33. Ratio power/volume [kW/l]:

0.80

30. Number of basins:

2

34. Drain type:

Trough the cabinet

31. Basket size [mm]:

2x 280 x 300 x 120

35. Drain:

Yes

32. Basin material:

AISI 304 - High quality stainless steel

36. Heating location:

Inside the tank